

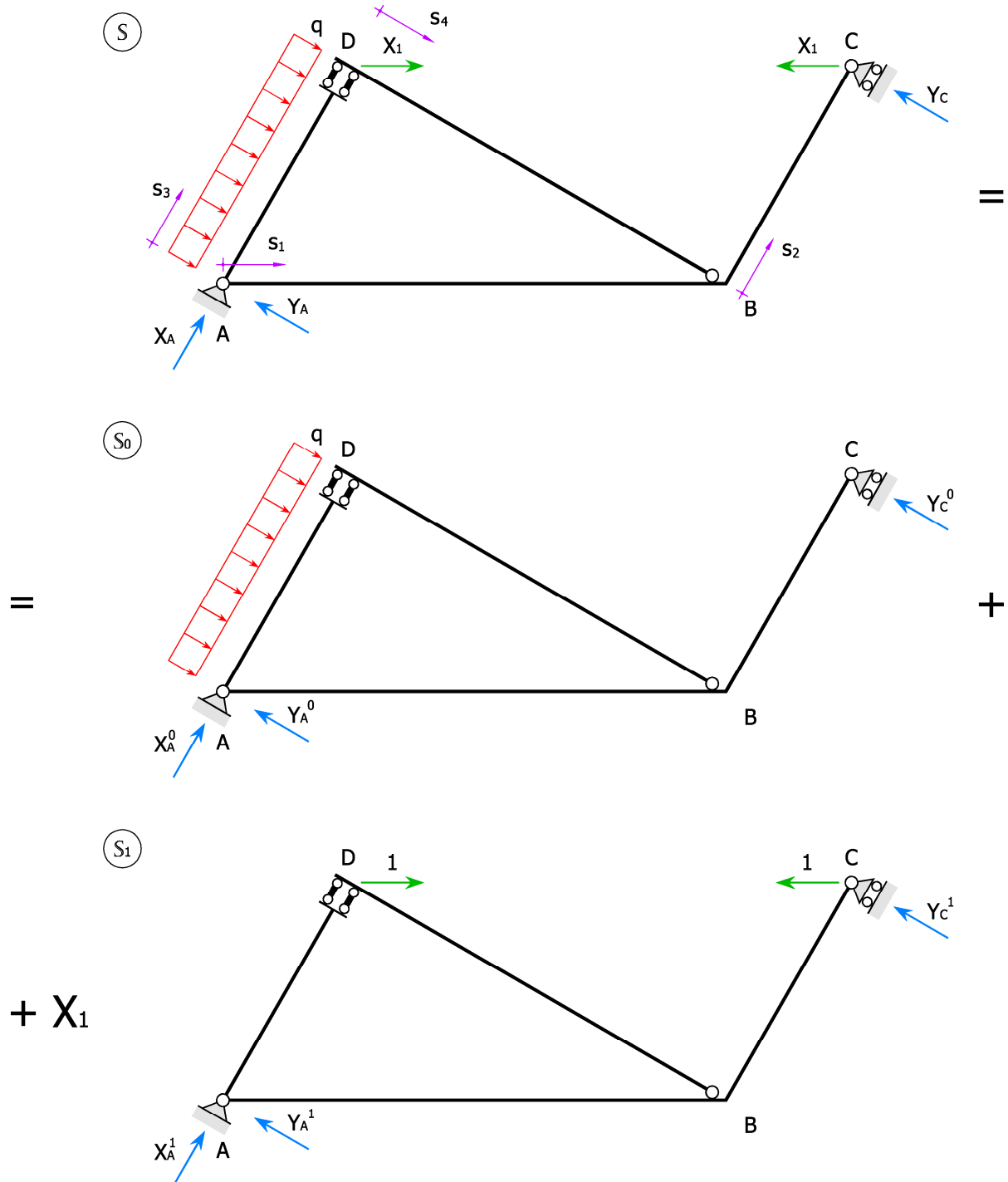

Prova scritta del 18 febbraio 2013 – Soluzione

Problema A

Assunta come incognita iperstatica X_1 la forza normale nell'asta CD, si decompone il sistema equivalente S nella somma del sistema S_0 e del sistema S_1 moltiplicato per X_1 .





Sistema S_0

Reazioni vincolari:

$$X_A^0 = 0, \quad Y_A^0 = \frac{3}{4}qL, \quad Y_C^0 = \frac{1}{4}qL.$$

Caratteristiche della sollecitazione:

Trave n.	Estremi IJ	Ascissa	Forza normale N_{IJ}^0	Forza di taglio T_{IJ}^0	Mom. flettente M_{IJ}^0
1	AB	$0 \leq s_1 \leq 2L$	$-\frac{5}{24}\sqrt{3}qL$	$\frac{1}{8}qL$	$\frac{1}{8}qLs_1$
2	BC	$0 \leq s_2 \leq L$	0	$-\frac{1}{4}qL$	$\frac{1}{4}qL^2 - \frac{1}{4}qLs_2$
3	AD	$0 \leq s_3 \leq L$	$\frac{\sqrt{3}}{6}qL$	$qL - qs_3$	$qLs_3 - \frac{1}{2}qs_3^2$
4	DB	$0 \leq s_4 \leq \sqrt{3}L$	0	$-\frac{\sqrt{3}}{6}qL$	$\frac{1}{2}qL^2 - \frac{\sqrt{3}}{6}qLs_4$

Diagrammi:

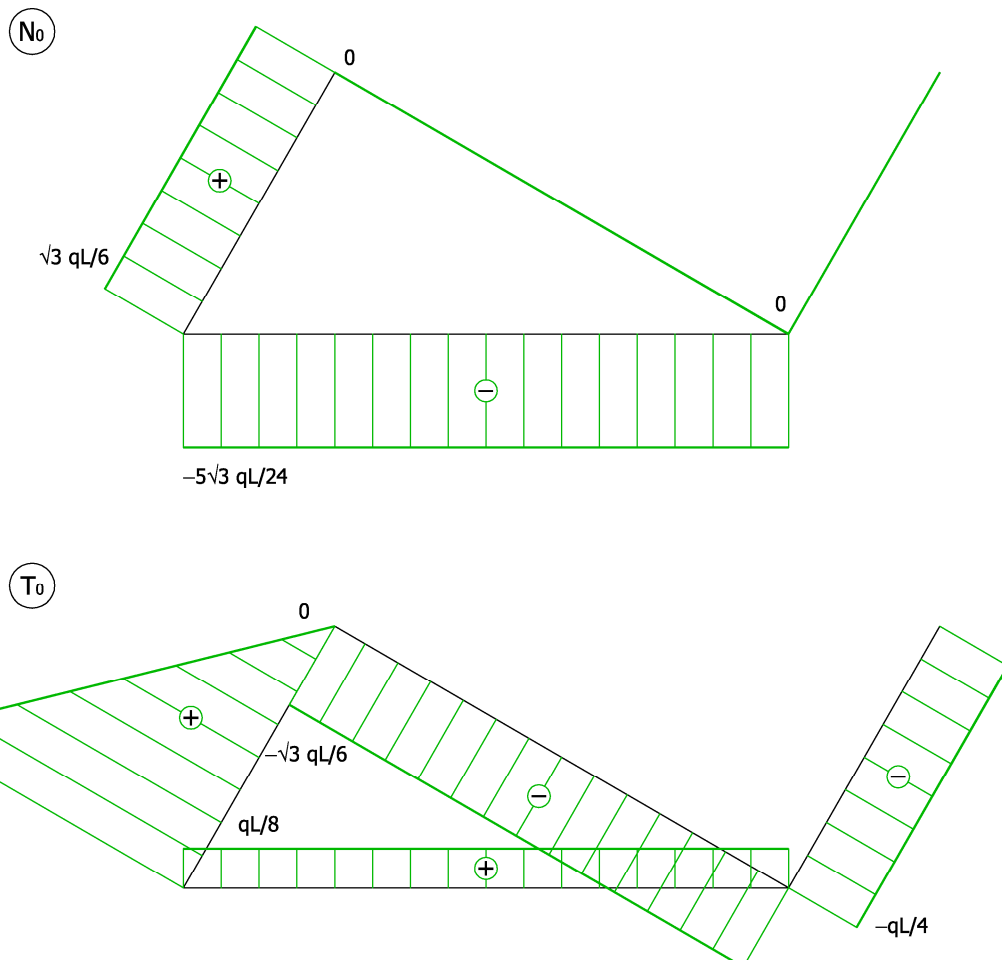



(M₀)

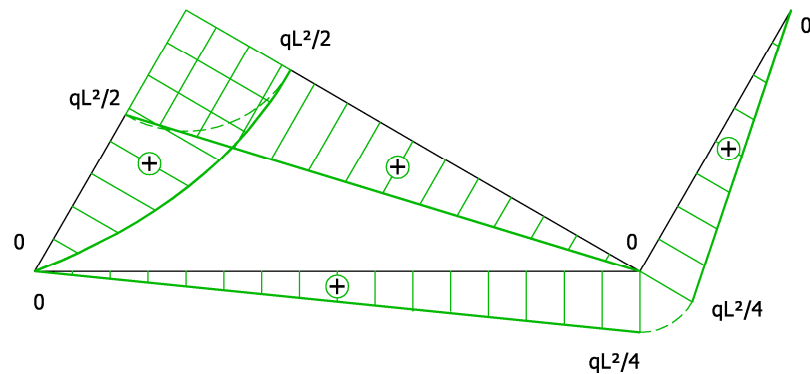

Sistema S₁

Reazioni vincolari:

$$X_A^1 = 0, \quad Y_A^1 = 0, \quad Y_B^1 = 0.$$

Caratteristiche della sollecitazione:

Trave n.	Estremi IJ	Ascissa	Forza normale N _D ¹	Forza di taglio T _D ¹	Mom. flettente M _D ¹
1	AB	$0 \leq s_1 \leq 2L$	$-\frac{1}{4}$	$\frac{\sqrt{3}}{4}$	$\frac{\sqrt{3}}{4}s_1$
2	BC	$0 \leq s_2 \leq L$	$-\frac{1}{2}$	$-\frac{\sqrt{3}}{2}$	$\frac{\sqrt{3}}{2}L - \frac{\sqrt{3}}{2}s_2$
3	AD	$0 \leq s_3 \leq L$	$\frac{1}{2}$	0	0
4	DB	$0 \leq s_4 \leq \sqrt{3}L$	$-\frac{\sqrt{3}}{2}$	0	0

Diagrammi:

(N₁)

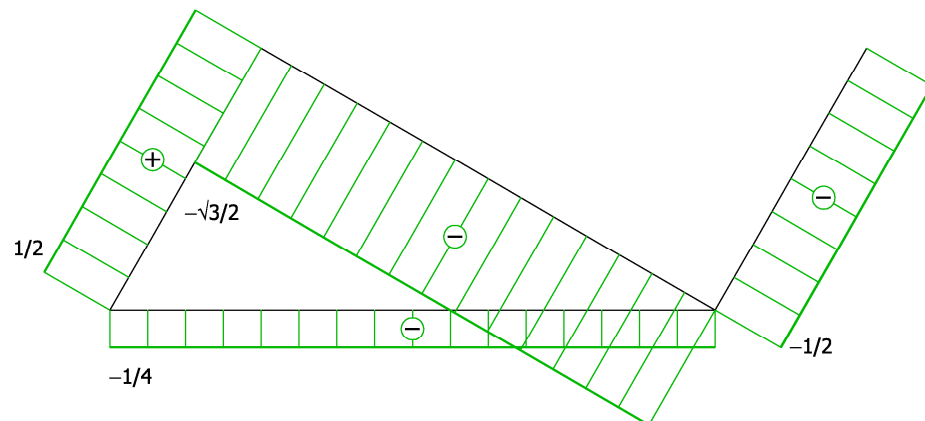



(T₁)

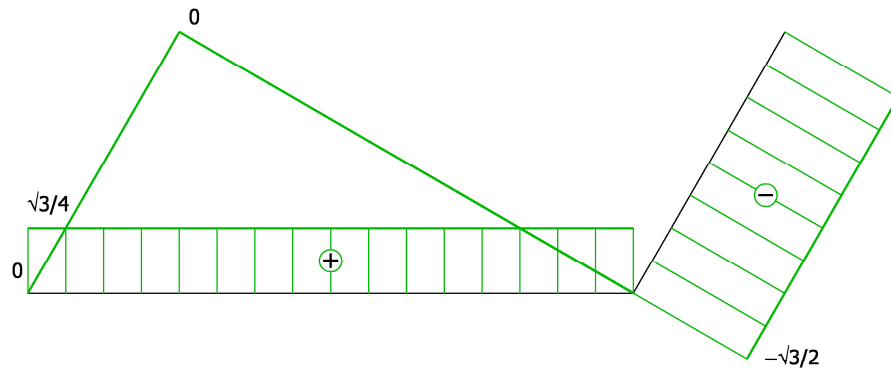

(M₁)

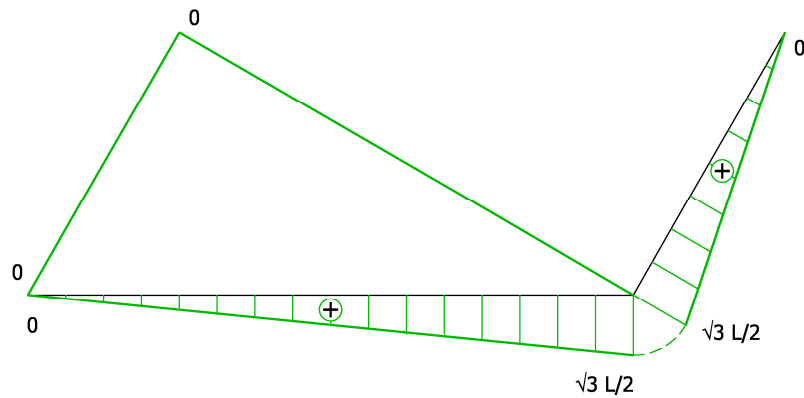

Determinazione dell'incognita iperstatica

Equazione di Müller-Breslau:

$$\eta_1 = \eta_{10} + X_1 \eta_{11} = -\frac{2L}{EA} X_1 + 2 \bar{\epsilon} L.$$

Teorema dei lavori virtuali:

$$\mathcal{L}_e^{1 \rightarrow 0} = 1 \cdot \eta_{10} = \mathcal{L}_1^{1 \rightarrow 0} = \int_{\Omega} M_D^1 \kappa_D^0 ds,$$

$$\mathcal{L}_e^{1 \rightarrow 1} = 1 \cdot \eta_{11} = \mathcal{L}_1^{1 \rightarrow 1} = \int_{\Omega} M_D^1 \kappa_D^1 ds.$$

Coefficienti:

$$\eta_{10} = \frac{\sqrt{3}}{8} \frac{qL^4}{EJ}, \quad \eta_{11} = \frac{3}{4} \frac{L^3}{EJ}.$$

Incognita iperstatica:

$$X_1 = -\frac{\sqrt{3} qL^3 - 16 EJ \bar{\epsilon}}{6 L^3 + 16 J/A}.$$



Problema B

Caratteristiche geometriche della sezione (il baricentro cade a metà altezza e gli assi x e y sono assi principali d'inerzia):

$$A = 18 at, \quad J_x = \frac{62}{3} a^3 t.$$

Caratteristiche della sollecitazione non nulle:

$$N = 12 P, \quad T_y = 24 P, \quad M_x = 36 Pa.$$

Tensioni sulle corde:

Corda	Ordinata	Momento statico	Tensione normale	Tensione tangenziale da taglio	Tensione ideale massima
n.	y	S_x^+	$\sigma_z = \frac{N}{A} + \frac{M_x}{J_x} y$	$\tau_{zn} = \frac{T_y S_x^+}{J_x t}$	$\sigma_{id} = \sqrt{\sigma_z^2 + 4\tau_{zn}^2}$
1	-a	$-\frac{5}{2} a^2 t$	$\left(\frac{2}{3} - \frac{54}{31}\right) \frac{P}{at}$	$-\frac{90}{31} \frac{P}{at}$	$5.905 \frac{P}{at}$
2	0	0	$\frac{2}{3} \frac{P}{at}$	0	$0.667 \frac{P}{at}$
3	a	$\frac{7}{2} a^2 t$	$\left(\frac{2}{3} + \frac{54}{31}\right) \frac{P}{at}$	$\frac{126}{31} \frac{P}{at}$	$8.478 \frac{P}{at}$
4	2a	$2 a^2 t$	$\left(\frac{2}{3} + \frac{108}{31}\right) \frac{P}{at}$	$\frac{72}{31} \frac{P}{at}$	$6.229 \frac{P}{at}$